

100 Series: Innovative Solutions

EXPERIENCE THE DIFFERENCE.



CS101



CS102



CS103



CS104



CS105



CS106



CS107



CS108



CS109



CS110



CS112



CS114

Meeting the needs of a 21st century care center takes experience and a commitment to excellence. CCI Group is proud to offer a line of Wall Mounted Computer Stations that meet your needs in a rapidly changing industry. Let our knowledgeable team guide you through the process from concept to installation. Experience solutions with integrity. Experience the difference. CCIGROUP.COM



100 Series

Wall Mounted Computer Station

Product Description

Don't compromise. Get the efficiency you need and the aesthetic you want in one space-saving design. Our 100 series offers a practical solution with interchangeable features to meet your unique healthcare needs.

Standard Features

- **Self Closing Keyboard Door** – Prevents damage from hallway traffic.
- **Space Saving Design** – Easily installed in busy hallways or patient rooms.
- **Durable Construction** – Postform end panels and 3mm edges help prevent damage to unit.
- **Integrated Cooling Fans** – Extend the life of the CPU.
- **Infection Control** – Smooth cleanable surfaces.
- **Cam Locks** – Security and control.
- **Warranty** – Limited two-year warranty.

Available Options

- **Automatic Monitor Shut-Off and LED Lighting**
- **Mechanical Push Button Lock**
- **Electronic Keypad Lock**
- **Magnetic Strip Card Lock**
- **Radio Frequency (RF) Card Lock**
- **Integrate Existing Locking System**
- **Recessed Design**
- **Scanner Storage/Shelf**
- **Thousands of Laminate Color Choices**
- **Additional Custom Options are also available**



Standard Laminate Color Selections



■ Figured Mahogany



■ Fusion Maple



■ Shaker Cherry

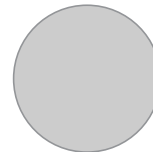

■ Fashion Grey



■ Wild Cherry

EXPERIENCE AND KNOWLEDGE COMBINED TO MEET EVERYDAY NEEDS



(903) 753.2488 | www.ccigroup.com | cci@ccigroup.com



400 Series: Innovative Solutions

EXPERIENCE THE DIFFERENCE.



CS402



CS407



CS410



CS412



CS415



CS420



CS425



CS431



CS446



CS460



CS462

Meeting the needs of a 21st century care center takes experience and a commitment to excellence. CCI Group is proud to offer a line of Wall Mounted Computer Stations that meet your needs in a rapidly changing industry. Let our knowledgeable team guide you through the process from concept to installation. Experience solutions with integrity. Experience the difference. CCIGROUP.COM



400 Series

Wall Mounted Computer Station

Product Description

The 400 series is designed to help you provide the very best in patient care. Utilizing a state-of-the-art arm, our most popular models combine generous maneuverability and an efficient profile that can be customized for your facility.

Standard Features

- **Flip-Down Work Surface** – Helps with medication prep and paperwork.
- **Space Saving Design** – Easily installed in patient rooms.
- **Durable Construction** – Postform end panels and 3mm edges help prevent damage to unit.
- **Integrated Cooling Fans** – Extend the life of the CPU.
- **Infection Control** – Smooth cleanable surfaces.
- **Cam Locks** – Security and control.
- **Warranty** – Limited two-year warranty.

Available Options

- Mechanical Push Button Lock
- Electronic Keypad Lock
- Magnetic Strip Card Lock
- Radio Frequency (RF) Card Lock
- Integrate Existing Locking System
- Integral Narcotics/Storage Box
- Scanner Storage/Shelf
- Various End Panel Designs
- Thousands of Laminate Color Choices
- Additional Custom Options are also available



Standard Laminate Color Selections



■ Figured Mahogany



■ Fusion Maple



■ Shaker Cherry

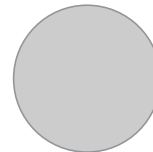

■ Fashion Grey



■ Wild Cherry

EXPERIENCE AND KNOWLEDGE COMBINED TO MEET EVERYDAY NEEDS



(903) 753.2488 | www.ccigroup.com | cci@ccigroup.com



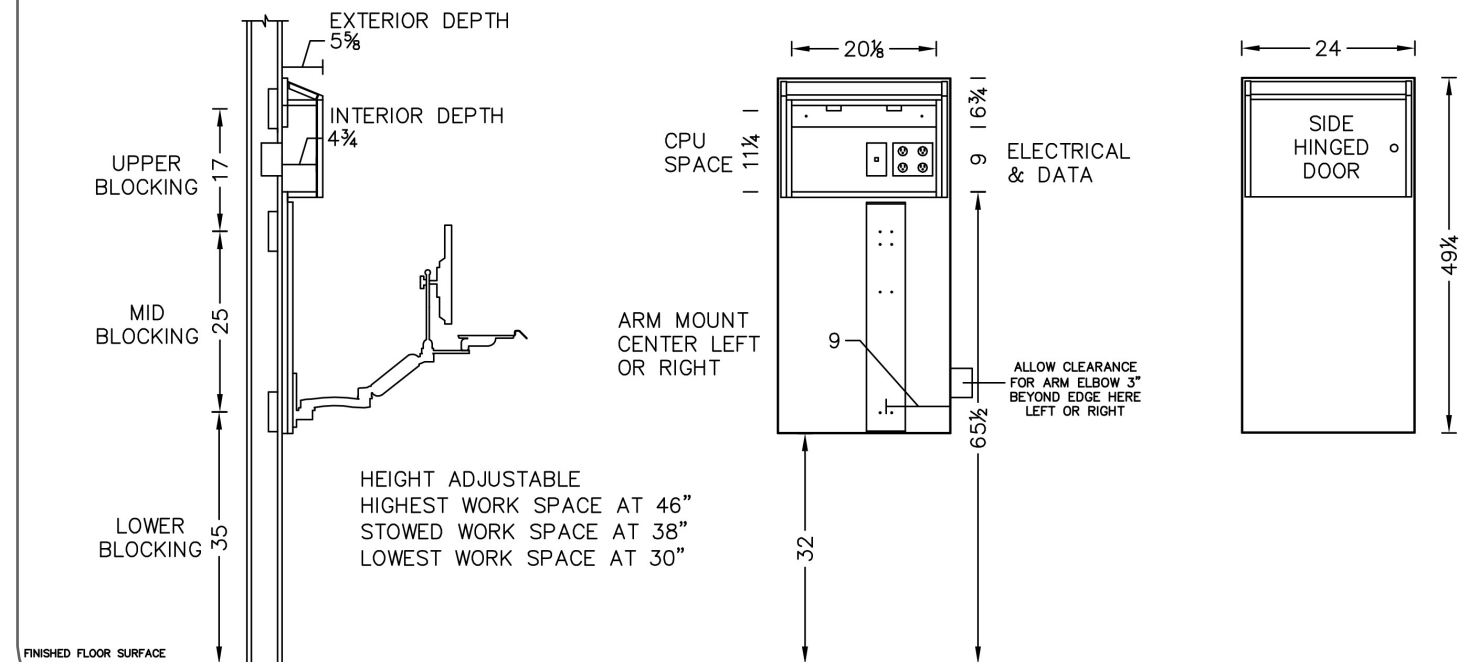

Standard Features

- Space Saving Design – Easily installed in alcoves, recesses, or patient rooms.
- Durable Construction – Postform end panels and thick edgebanding on doors help prevent damage to unit.
- Integrated Cooling Fans – Extend the life of the CPU.
- Infection Control – Smooth cleanable surfaces.
- Cam Locks – Security and control.
- Limited Two-Year Warranty

Available Options

- Electronic Keypad Lock
- Thousands of Laminate Color Choices
- Optional scanner mount and work surface available

Monitor Arm

- Extends up to 42 inches
- 16 inches of Height Adjustment
- Flip-Down Keyboard Tray

Finished Dimensions

- Width : 24"
- Height : 49 1/4"
- Depth : 5 5/8"

Product Description

Utilizing a state-of-the-art arm and track system, the CS462 provides generous maneuverability, height adjustment and an efficient profile. This unit is 5-5/8" deep with CPU storage at the top. The CS462 is designed for use in healthcare environments and patient rooms.

Industry-leading reach and adjustability



Elite 5216 Sit-Stand Workstation

Compact. Ergonomic. Hygienic. Versatile.

- **COMPACT.** Ideal for space-constrained areas. Extends a monitor and keyboard up to 69", then stows compactly against the wall.
- **ERGONOMIC.** Provides effortless movement and is fully adjustable at each joint for maximum ergonomic comfort. Rotates 180° at the wall mount.
- **HYGIENIC.** Full cable management allows for thorough disinfection, protects wires, and creates a neater appearance.
- **VERSATILE.** Excels in a wide variety of applications. Can be mounted on a desk, pole, wall or wall track.

Monitor, keyboard and mouse not included.

Specifications

Load capacity	28 lbs (12.7 kg) Monitor only 22 lbs (9.9 kg) Monitor and keyboard
Vertical adjust range	30" (76 cm)
Maximum reach	43" (109 cm) Monitor only 58" (147 cm) Monitor and Flip Up Tray 64" (162.6 cm) Monitor and Keyboard Ultra Slide 69" (175 cm) Monitor and WorkSurface
Stowed depth	11" (28 cm)
Horizontal rotation	180° at wall
Screen swivel	360°
Screen tilt	50°
VESA interface	75 mm and 100 mm



For more information contact your ICW representative or talk to one of our customer service representatives at 1-800-558-4435.

Range of Motion Video



Range of Motion and Dimension Drawings

Industry-leading horizontal reach

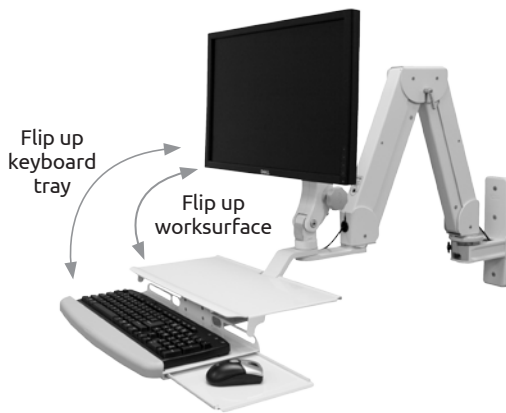
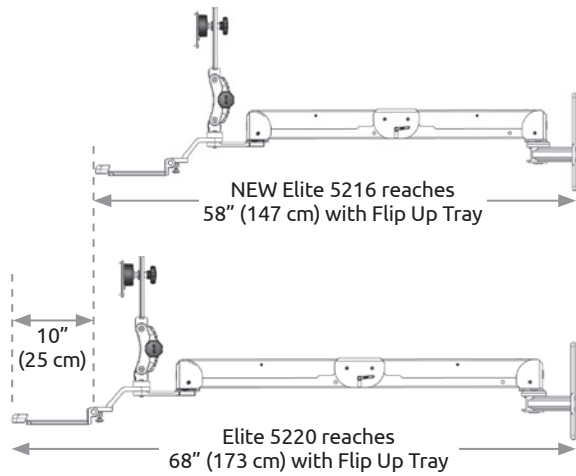

NEW Keyboard Ultra Slide

ELP5216-WT-KUS

- Surface for charting, scanning, holding meds
- Mouse tray pulls out on both sides
- Accommodates most standard keyboards

Available options

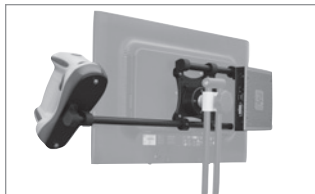

Behind-the-MONITOR scanner and/or Mini-PC mount



Behind-the-KEYBOARD scanner mount

Industry-leading adjustability

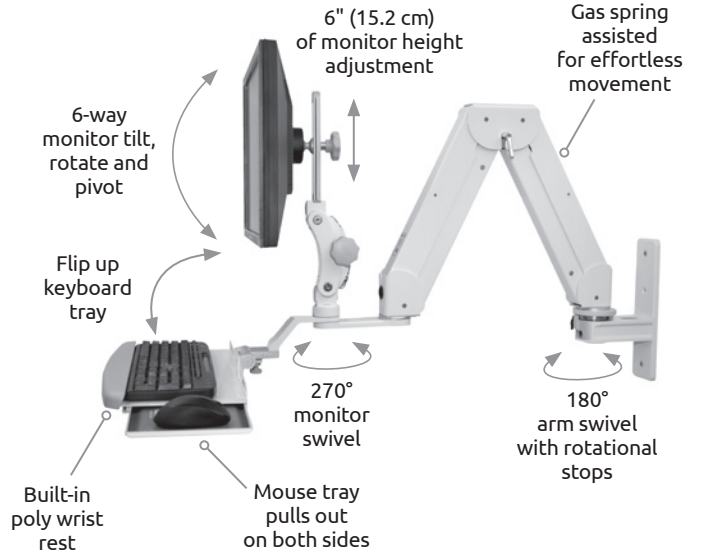

Flip Up Keyboard Tray

ELP5216-WT-KUB

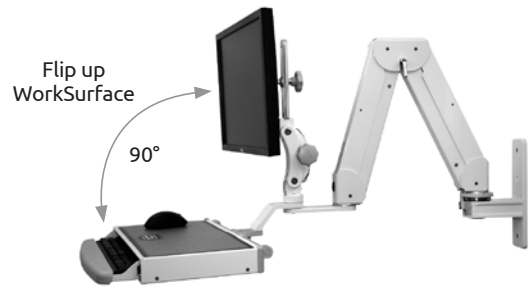

NEW WorkSurface Tray

ELP5216-WT-KUW

- Large surface for charting, scanning, and mousing
- Flips up 90° to stow compactly
- Accommodates most standard keyboards

True sit-stand workstation



Stowable

All Models stow tightly against the wall

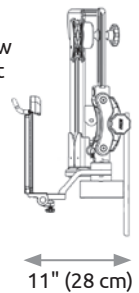

ICWUSA.com, Inc.
1487 Kingsley Drive
Medford, OR 97504
800-558-4435

Available in these 5 standard colors and 9 custom colors.





The Ultra arm is protected by U.S. Patent 9,243,743

Create your ultimate workstation with the unique, patented Ultra 180 system

- **SLEEK, VERSATILE DESIGN.** The Ultra 180 can be configured to your specific needs. Ideal for computer workstations and for mounting medical and industrial devices.
- **ERGONOMIC.** Relieve eye, neck and back strain by easily moving arm to the most comfortable position. Keyboard adjusts to positive, neutral, and negative tilt for maximum ergonomic benefit.
- **MONITOR ROTATES** for portrait viewing of images and pages. Eliminates scrolling.
- **EXTENDS AND RETRACTS.** Effortlessly push your display out of the way when it's not in use.
- **COMPACT.** The Ultra 180 stows just 10" (25.4 cm) from the mounting surface, making it the perfect choice for tight spaces.

Specifications—Ultra 180

Load capacity	32 lbs (14.5 kg)
Vertical adjustment range	16" (40.6 cm)
Reach of 180 Arm	16" (40.6 cm)
Stowed depth	10" (25.4 cm)
Horizontal rotation at wall	180°
Horizontal rotation at A1 joint	270°
Monitor tilt	50°
Monitor swivel	270°
Monitor rotation	Landscape to portrait position
VESA interface	75 mm and 100 mm

Monitor, keyboard and mouse not included



For more information contact your ICW representative or talk to one of our customer service representatives at 1-800-558-4435.

Range of Motion Video



Industry-leading range of motion. Extensive configurations and versatility.

The ONLY arm with full 180° of vertical rotation and up to 360° of horizontal rotation.

Industry-leading vertical range of motion

UL180EV7-W3-KUB-A1

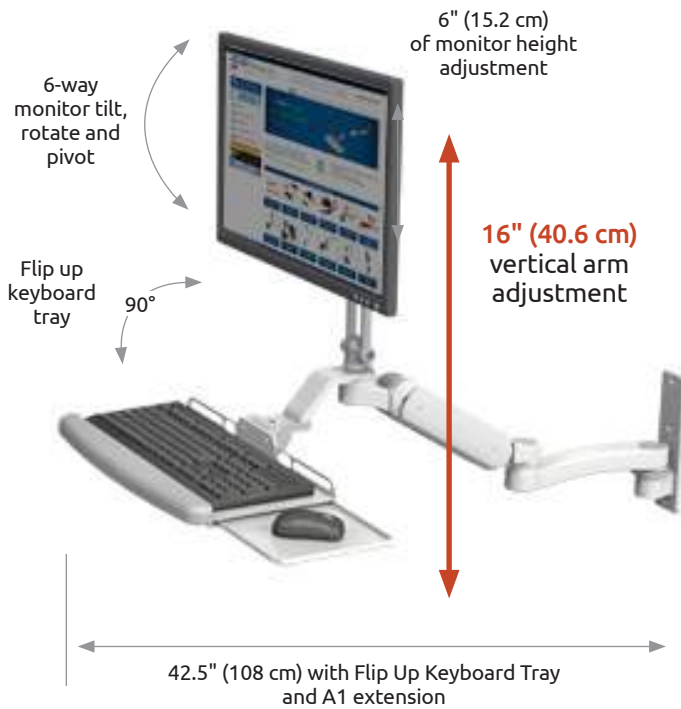

Industry-leading horizontal range of motion

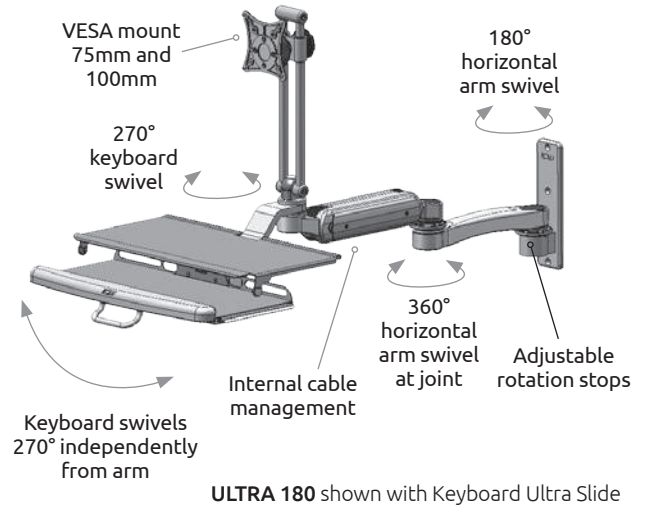

UL180P-W3-KUB-AS1
Ultra 180 shown with Dual Monitors, Flip Up Keyboard Tray, and AS1 extension mounted at the front of the arm.



UL180EV7-W3-KUW-A1
Ultra 180 shown with WorkSurface Tray and A1 extension mounted at the back of the arm.



DUAL ULTRA 180 WORKSTATION
Monitor and WorkSurface Tray mounted on separate Ultra 180 arms with A1 extensions.



UL180iEV7-W3-KUB-A1
Inverted Ultra 180 shown with Flip Up Keyboard Tray and Service Tray with A1 extension mounted at the back of the arm.



ICWUSA.com, Inc.
1487 Kingsley Drive
Medford, OR 97504
800-558-4435

Available in these 5 standard colors and 9 custom colors.



Available in three models: VT21, VTLP Low Profile, VTTM Dual Arm

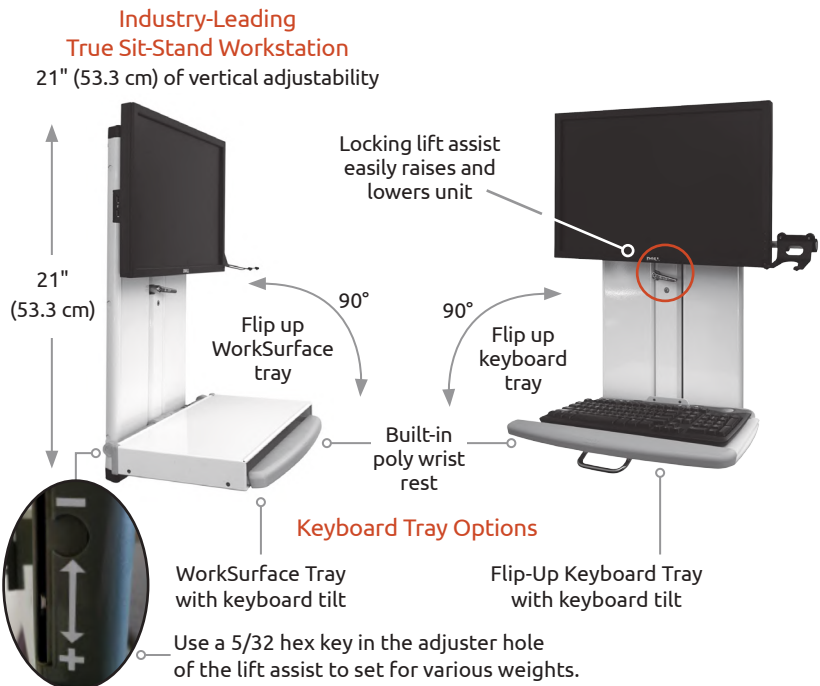

"The doctor noticed the stowed unit didn't stick out much farther than the hand sanitizer."

VT21 Low Profile Workstation

Stows in as little as 4" (10 cm) from the wall

- **COMPACT.** The Low Profile model stows just 4" (10 cm) from the mounting surface. The stowed depth of the VT21 is 5.5" (14 cm), and the stowed depth of the Dual Arm model is 7.5" (19 cm).
- **TRUE SIT-STAND.** All models provide 21" of vertical adjustment for comfort both standing and sitting.
- **EASY WEIGHT ADJUSTMENT.** Lift assist is adjustable for various monitor and keyboard weights using a hex key in the adjuster hole in the lower left end cap. The handy adjustment indicator on the left side shows the degree of lift assist being used.
- **SMOOTH HEIGHT ADJUSTMENT.** Locking Lift Assist easily raises and lowers unit. Locks securely at desired height.
- **ADJUSTABLE MONITOR** with two height settings.
- **ERGONOMIC.** The WorkSurface Tray and/or Flip-Up Keyboard Tray can both be adjusted to positive, neutral, and negative tilt for greatest ergonomic comfort.
- **HYGIENIC.** Durable, easy-to-clean finish withstands harsh chemicals. Built with smooth aircraft-grade aluminum that doesn't allow microorganisms to hide.

Monitor, keyboard and mouse not included.

Specifications for all models

Adjustable Load capacity	10-25 lbs (4.5-11.3 kg)	
Dimensions	14" wide x 30" high (35.6 cm x 76 cm)	
Vertical adjust range	All models: 21" (53.3 cm)	
Depth with WorkSurface Tray extended	VT21	22" (56 cm)
	VTLP Low Profile	22" (56 cm)
	VTTM Dual Arm	36" (91.4 cm)
Depth with Flip-Up Keyboard Tray	VT21	12" (30.5 cm)
	VTLP Low Profile	12" (30.5 cm)
	VTTM Dual Arm	26" (66 cm)
Stowed depth	VT21	5.5" (14 cm)
	VTLP Low Profile	4" (10 cm)
	VTTM Dual Arm	7.5" (19 cm)
Horizontal rotation of mount	VT21	None
	VTLP Low Profile	None
	VTTM Dual Arm	180° at wall
Monitor rotation	VT21	360°
	VTLP Low Profile	None
	VTTM Dual Arm	360°
Monitor tilt	VT21	50°
	VTLP Low Profile	None
	VTTM Dual Arm	50°
VESA interface	75 mm and 100 mm	

Range of Motion Video



For more information contact your ICW representative or talk to one of our customer service representatives at 1-800-558-4435.

Range of Motion and Dimension Drawings

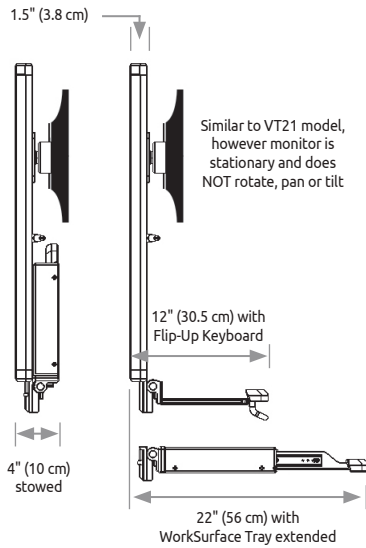

VTLP Low Profile

- Depth with WorkSurface Tray extended: 22" (56 cm)
- Depth with Flip-Up Keyboard Tray: 12" (30.5 cm)
- Stowed depth: 4" (10 cm)
- Mounts flat against the wall
- Monitor does not rotate or tilt

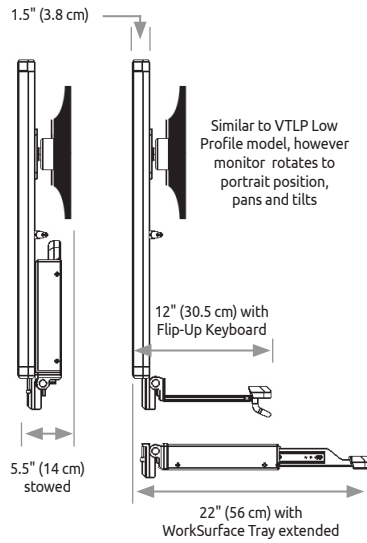

VT21

- Depth with WorkSurface Tray extended: 22" (56 cm)
- Depth with Flip-Up Keyboard Tray: 12" (30.5 cm)
- Stowed depth: 5.5" (14 cm)
- Mounts flat against the wall
- Monitor rotates to portrait position, pans and tilts

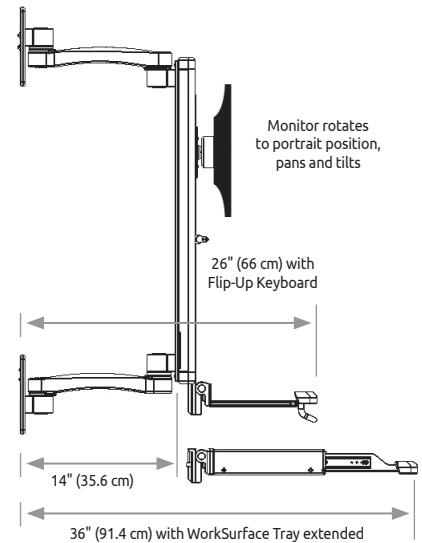

VTTM Dual Arm

- Depth with WorkSurface Tray extended: 36" (91.4 cm)
- Depth with Flip-Up Keyboard Tray: 26" (66 cm)
- Stowed depth: 7.5" (19 cm)
- Mounts with two extension arms
- Horizontal swivel of arms at mount: 180°
- Monitor rotates to portrait position, pans and tilts



Image shows a stowed VT21.

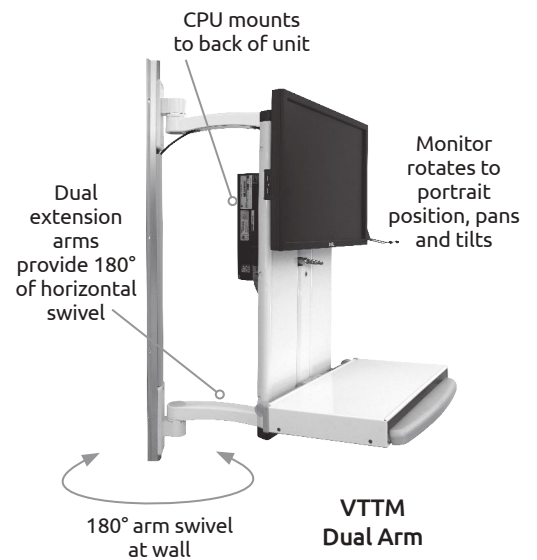
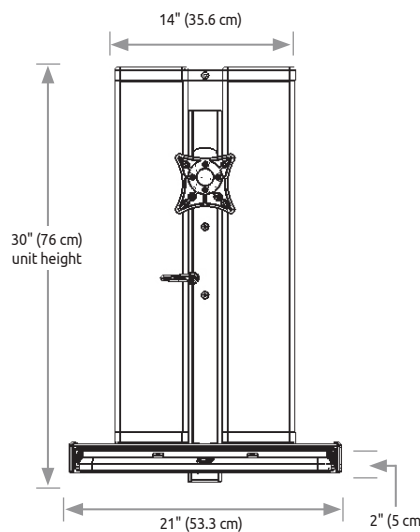

ICWUSA.com, Inc.
1487 Kingsley Drive
Medford, OR 97504
800-558-4435

Available in these 5 standard colors and 9 custom colors.

